

# TUBE / PIPE BEVELLING MACHINE FM-24000

Combination of Power and Wide Range

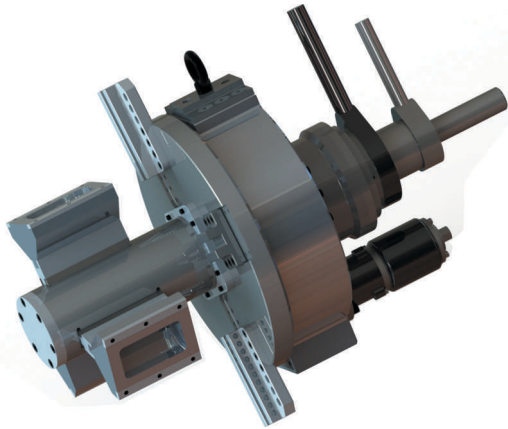

**FMP-24000 PNEUMATIC**

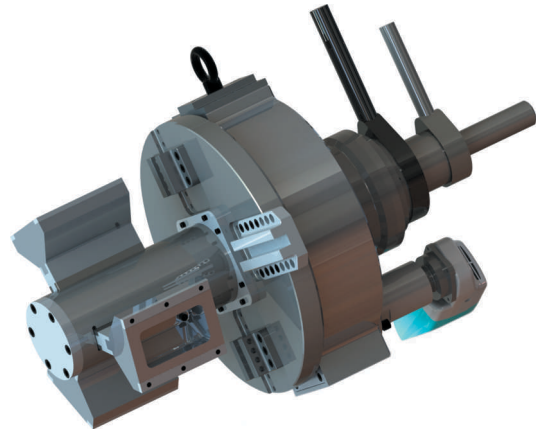

**FME-24000 ELECTRIC**

The FM-24000 is a combination of power and range in a light and portable design. Rugged and balanced machine suitable for tubes and pipes in the size range of 180mm to 609mm in internal diameter.

## Features of Tube End Facing Machine - FM-24000

**TOOL HOLDER** - Holds the cutting tool bits tightly at the desired position. Its robust construction and support to the cutting bits ensure vibration free performance.

**FEED SHAFT** - High strength, precise machined and hardened feed shaft provides powerful feeding to the assembly which slides over it.

**JAW** - Wedge style hardened tool steel mounted jaws for maximum life and secure positioning. Available within the locking range of 180mm to 609mm.

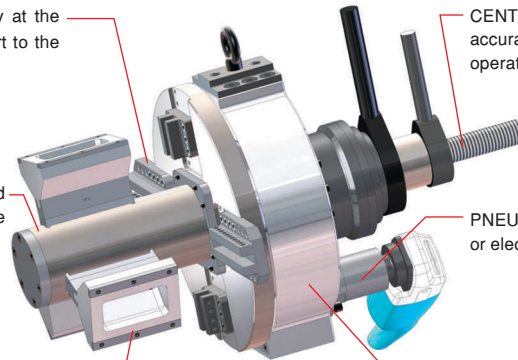

**CENTRAL MANDREL** - Expanding mandrel allows fast, accurate and self-centering alignment with torque-free operation for operator safety.

**PNEUMATIC OR ELECTRIC DRIVE** - High quality pneumatic or electric drive for reliable service and long working life.

**BODY** - Light weight, high pressure cast aluminum body allows continuous operation under the harshest conditions.

## Technical Specification

Drive		Pneumatic	Electric
Locking Range	mm (inch)	180 - 609 (7" - 24")	180 - 609 (7" - 24")
Idle Speed	rpm	10	13
Torque	Nm (lbf.ft)	3376 (2490)	1400 (1032)
Feeding Stroke	mm (inch)	60 (2.36")	60 (2.36")
Pneumatic Power	HP	3.5	-
Air Consumption	cfm	95	-
Air Pressure	bar (psi)	6.2 (90)	-
Electric Power	Watts	-	3.5
Voltage	V	-	110 / 230
Net Weight	kg (lb)	250 (550)	250 (550)

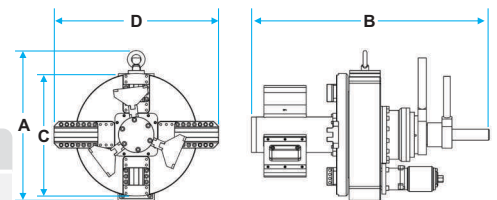

	PNEUMATIC (mm)	ELECTRIC (mm)
A	600	600
B	975	975
C	500	500
D	674	674